

Product Data

Convertible Air Handlers 1-1/2 – 5 Ton

TEM4A0B18S21SB
TEM4A0B24S21SB
TEM4A0B30S31SB
TEM4A0B36S31SB
TEM4A0C37S31SB
TEM4A0C42S41SB
TEM4A0C48S41SB
TEM4A0C60S51SB

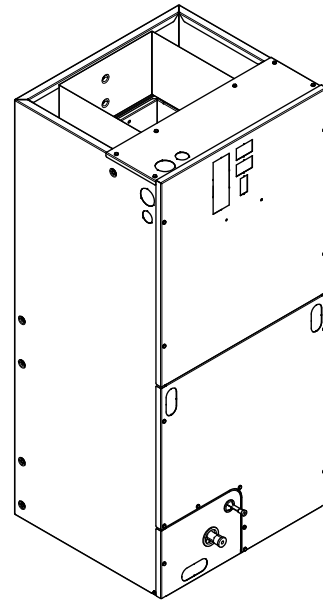

The TEM4 series air handler is designed for installation in a closet, utility room, alcove, basement, crawlspace or attic. These versatile units are applicable to air conditioning and heat pump applications. Several models are available to meet the specific requirements of the outdoor equipment. Field installed electric resistance heaters are available.

Table of Contents

Features and Benefits	3
Optional Equipment	3
Product Specifications	4
Heater Pressure Drop Table TEM Air Handler Models	6
Minimum Airflow CFM	7
Air Handler and Heater Matrix Allowable Combinations	8
Performance and Electrical Data	9
Electrical Data	15
Field Wiring	16
TEM Convertibility	17
TEM4 Air Handler Dimensional Data	18
Outline Drawing	19

Features and Benefits

- Painted metal cabinet with captured foil face insulation
- 2% or less air leakage
- R-4.2 Insulating Value
- Multi-Position UP/Down Flow, Horizontal Left /Right
- ALL Aluminum Coil with Enhanced Patented Coil Fin
- Electric Heaters with polarized plug connections (sold as accessory)
- R-410A Thermal Expansion Valve
- ECM Motor **(3.5 – 5 Ton Models)**
- Low Voltage Pigtail Connections
- Draw Through Design
- Horizontal Drain pan
- Fused 24V Power
- **3 year warranty**
- **10-year warranty registered**
- **Optional extended warranty available**

Important: Condensate management kit is required for all 5 ton air handler models installed in downflow applications.

Optional Equipment

Accessory Number	Description	Fits Cabinet Size
BAYHTR1504BRK	Electric Heater, 4KW, Breaker, 24V Control, 1 Ph	18.5" and 23.5"
BAYHTR1504PDC	Electric Heater, 4KW, Pull Disconnect, 24V Control, 1 Ph	18.5" and 23.5"
BAYHTR1504LUG	Electric Heater, 4KW, Lug, 24V Control, 1 Ph	18.5" and 23.5"
BAYHTR1505BRK	Electric Heater, 5KW, Breaker, 24V Control, 1 Ph	18.5" and 23.5"
BAYHTR1505PDC	Electric Heater, 5KW, Pull Disconnect, 24V Control, 1 Ph	18.5" and 23.5"
BAYHTR1505LUG	Electric Heater, 5KW, Lug, 24V Control, 1 Ph	18.5" and 23.5"
BAYHTR1508BRK	Electric Heater, 8KW, Breaker, 24V Control, 1 Ph	18.5" and 23.5"
BAYHTR1508PDC	Electric Heater, 8KW, Pull Disconnect, 24V Control, 1 Ph	18.5" and 23.5"
BAYHTR1508LUG	Electric Heater, 8KW, Lug, 24V Control, 1 Ph	18.5" and 23.5"
BAYHTR1510BRK	Electric Heater, 10KW, Breaker, 24V Control, 1 Ph	18.5" and 23.5"
BAYHTR1510PDC	Electric Heater, 10KW, Pull Disconnect, 24V Control, 1 Ph	18.5" and 23.5"
BAYHTR1510LUG	Electric Heater, 10KW, Lug, 24V Control, 1 Ph	18.5" and 23.5"
BAYHTR3510LUG	Electric Heater, 10KW, Lug, 24V Control, 3 Ph	18.5" and 23.5"
BAYHTR1515BRK	Electric Heater, 15KW, Breaker, 24V Control, 1 Ph	18.5" and 23.5"
BAYHTR1517BRK	Electric Heater, 15KW, Breaker, 24V Control, 1 Ph	18.5" and 23.5"
BAYHTR3515LUG	Electric Heater, 15KW, Lug, 24V Control, 3 Ph	18.5" and 23.5"
BAYHTR3517LUG	Electric Heater, 15KW, Lug, 24V Control, 3 Ph	18.5" and 23.5"
BAYHTR1519BRK	Electric Heater, 20KW, Breaker, 24V Control, 1 Ph	18.5"
BAYHTR1520BRK	Electric Heater, 20KW, Breaker, 24V Control, 1 Ph	23.5"
BAYHTR1521BRK	Electric Heater, 20KW, Breaker, 24V Control, 1 Ph	23.5"
BAYHTR1523BRK	Electric Heater, 20KW, Breaker, 24V Control, 1 Ph	23.5"
BAYHTR1525BRK	Electric Heater, 25KW, Breaker, 24V Control, 1 Ph	23.5"
BAYTEMSPFG1A	Supply Duct Flange Kit	18.5" and 23.5"
BAYSPEKT201A	Single Point Power Entry Kit	18.5" and 23.5"
BAYTEMDFKT1A ^(a)	Downflow Condensate Management Kit	23.5" (5 Ton only)
TAYBASE185	Air Handler Downflow Sub-Bases	18.5"
TAYBASE235 (TAYBASE 100)	Air Handler Downflow Sub-Bases	23.5"
BAYSF1185AAA	Slim Fit Filter Box	18.5"
BAYSF1235AAA	Slim Fit Filter Box	23.5"
TEMBRKSEALT01A	Breaker Seal Kit for sure with BAYHTR15 4kW — 20kW Heaters	18.5" and 23.5"
TEMBRKSEALT25A	Breaker Seal Kit for use with 25 kW electric heaters & heater kits used with BAYSPEKT201	18.5" and 23.5"

^(a) Required with all 5-ton air handler models in downflow orientation.

Product Specifications

MODEL	TEM4A0B18S21SB	TEM4A0B24S21SB	TEM4A0B30S31SB	TEM4A0B36S31SB
RATED VOLTS/PH/HZ	208-230/1/60	208-230/1/60	208-230/1/60	208-230/1/60
RATINGS ^(a)	See O.D. Specifications	See O.D. Specifications	See O.D. Specifications	See O.D. Specifications
INDOOR COIL — Type	Plate Fin	Plate Fin	Plate Fin	Plate Fin
Rows — F.P.I.	3 - 14	3 - 14	3 - 14	3 - 14
Face Area (sq. ft.)	4.37	4.37	4.37	4.37
Tube Size (in.)	3/8	3/8	3/8	3/8
Refrigerant Control	TXV	TXV	TXV	TXV
Drain Conn. Size (in.) ^(b)	3/4 NPT	3/4 NPT	3/4 NPT	3/4 NPT
DUCT CONNECTIONS	See Outline Drawing	See Outline Drawing	See Outline Drawing	See Outline Drawing
INDOOR FAN — Type	Centrifugal	Centrifugal	Centrifugal	Centrifugal
Diameter-Width (In.)	11 X 6	11 X 6	11 X 8	11 X 8
No. Used	1	1	1	1
Drive - No. Speeds	Direct - 3	Direct - 3	Direct - 3	Direct - 3
CFM vs. in. w.g.	See Fan Performance Table	See Fan Performance Table	See Fan Performance Table	See Fan Performance Table
No. Motors — H.P.	1 - 1/5	1 - 1/5	1 - 1/3	1 - 1/3
Motor Speed R.P.M.	825	825	825	825
Volts/Ph/Hz	208-230/1/60	208-230/1/60	208-230/1/60	208-230/1/60
F.L. Amps	1.2	1.2	2.0	2.0
FILTER				
Filter Furnished? ^(c)	No	No	No	No
REFRIGERANT	R-410A	R-410A	R-410A	R-410A
Ref. Line Connections	Brazed	Brazed	Brazed	Brazed
Coupling or Conn. Size — in. Gas	3/4	3/4	3/4	3/4
Coupling or Conn. Size — in. Liq.	3/8	3/8	3/8	3/8
DIMENSIONS	H x W x D	H x W x D	H x W x D	H x W x D
Crated (In.)	46 x 21 x 24	46 x 21 x 24	46 x 21 x 24	46 x 21 x 24
Uncrated	45-1/8 x 18-1/2 x 21-1/8	45-1/8 x 18-1/2 x 21-1/8	45-1/8 x 18-1/2 x 21-1/8	45-1/8 x 18-1/2 x 21-1/8
WEIGHT				
Shipping (Lbs.) / Net (Lbs.)	116/110	116/110	116/110	116/110

^(a) These Air Handlers are A.H.R.I certified with various Split System Air Conditioners and Heat Pumps (AHRI STANDARD 210/240). Refer to the Split System Outdoor Unit Product Data Guides for performance data.

^(b) 3/4" Male Plastic Pipe (Ref: ASTM 1785-76)

^(c) Remote filter required.

Product Specifications

MODEL	TEM4A0C37S31SB	TEM4A0C42S41SB	TEM4A0C48S41SB	TEM4A0C60S51SB
RATED VOLTS/PH/HZ	208-230/1/60	208-230/1/60	208-230/1/60	208-230/1/60
RATINGS^(a)	See O.D. Specifications	See O.D. Specifications	See O.D. Specifications	See O.D. Specifications
INDOOR COIL — Type	Plate Fin	Plate Fin	Plate Fin	Plate Fin
Rows — F.P.I.	3 - 14	3 - 14	3 - 14	4 - 14
Face Area (sq. ft.)	5.50	5.50	5.50	5.91
Tube Size (in.)	3/8	3/8	3/8	3/8
Refrigerant Control	TXV	TXV	TXV	TXV
Drain Conn. Size (in.) ^(b)	3/4 NPT	3/4 NPT	3/4 NPT	3/4 NPT
DUCT CONNECTIONS	See Outline Drawing	See Outline Drawing	See Outline Drawing	See Outline Drawing
INDOOR FAN — Type	Centrifugal	Centrifugal	Centrifugal	Centrifugal
Diameter-Width (In.)	11 X 8	11 X 8	11 X 8	11 X 8
No. Used	1	1	1	1
Drive - No. Speeds	Direct - 3 ^(c)	Direct - 3 ^(c)	Direct - 3 ^(c)	Direct - 3 ^(c)
CFM vs. in. w.g.	See Fan Performance Table	See Fan Performance Table	See Fan Performance Table	See Fan Performance Table
No. Motors — H.P.	1 - 1/3	1 - 1/2	1 - 3/4	1 - 3/4
Motor Speed R.P.M.	825	1050	1050	1050
Volts/Ph/Hz	208-230/1/60	208-230/1/60	208-230/1/60	208-230/1/60
F.L. Amps	2.5	4.1	6.0	6.0
FILTER				
Filter Furnished? ^(d)	No	No	No	No
REFRIGERANT	R-410A	R-410A	R-410A	R-410A
Ref. Line Connections	Brazed	Brazed	Brazed	Brazed
Coupling or Conn. Size — in. Gas	7/8	7/8	7/8	7/8
Coupling or Conn. Size — in. Liq.	3/8	3/8	3/8	3/8
DIMENSIONS	H x W x D	H x W x D	H x W x D	H x W x D
Crated (In.)	52-1/2 x 26 x 24	52-1/2 x 26 x 24	52-1/2 x 26 x 24	52-1/2 x 26 x 24
Uncrated	51-3/8 x 23-1/2 x 21-1/8	51-3/8 x 23-1/2 x 21-1/8	51-3/8 x 23-1/2 x 21-1/8	51-3/8 x 23-1/2 x 21-1/8
WEIGHT				
Shipping (Lbs.) / Net (Lbs.)	145/138	145/138	145/138	145/138

^(a) These Air Handlers are A.H.R.I certified with various Split System Air Conditioners and Heat Pumps (AHRI STANDARD 210/240). Refer to the Split System Outdoor Unit Product Data Guides for performance data.

^(b) 3/4" Male Plastic Pipe (Ref: ASTM 1785-76)

^(c) ECM Motor

^(d) Remote filter required.

Heater Pressure Drop Table TEM Air Handler Models

Airflow CFM	Number of Racks				Heater Racks	
	1	2	3	4	Heater Model	No. of Racks
	Air Pressure Drop — Inches W.G.					
1800	0.02	0.04	0.06	0.14	BAYHTR1504	1
1700	0.02	0.04	0.06	0.14	BAYHTR1505	1
1600	0.02	0.04	0.06	0.13	BAYHTR1508	2
1500	0.02	0.04	0.06	0.12	BAYHTR1510	2
1400	0.02	0.04	0.06	0.12	BAYHTR3510	3
1300	0.02	0.04	0.05	0.11	BAYHTR1515	3
1200	0.01	0.04	0.05	0.10	BAYHTR1517	3
1100	0.01	0.03	0.05	0.09	BAYHTR3515	3
1000	0.01	0.03	0.04	0.09	BAYHTR3517	3
900	0.01	0.03	0.04	0.08	BAYHTR1519	4
800	0.01	0.03			BAYHTR1520	4
700	0.01	0.02			BAYHTR1521	4
600	0.01	0.02			BAYHTR1523	4
					BAYHTR1525	4

Minimum Airflow CFM

TEM4A0B18S21SB, TEM4A0B24S21SB		
Heater	Minimum Heat Speed Tap	
	With Heat Pump	Without Heat Pump
BAYHTR1504BRK, BAYHTR1504LUG, BAYHTR1505BRK, BAYHTR1505LUG	Med	Low
BAYHTR1508BRK, BAYHTR1508LUG, BAYHTR1510BRK, BAYHTR1510LUG, BAYHTR3510LUG	Med	Low

TEM4A0B30S31SB, TEM4A0B36S31SB		
Heater	Minimum Heat Speed Tap	
	With Heat Pump	Without Heat Pump
BAYHTR1504BRK, BAYHTR1504LUG, BAYHTR1505BRK, BAYHTR1505LUG	Low	Low
BAYHTR1508BRK, BAYHTR1508LUG, BAYHTR1510BRK, BAYHTR1510LUG, BAYHTR3510LUG	Low	Low
BAYHTR1517BRK	Med	Low
BAYHTR3517LUG	High	Low

TEM4A0C37S31SB		
Heater	Minimum Heat Speed Tap	
	With Heat Pump	Without Heat Pump
BAYHTR1504BRK, BAYHTR1504LUG, BAYHTR1505BRK, BAYHTR1505LUG	Low	Low
BAYHTR1508BRK, BAYHTR1508LUG, BAYHTR1510BRK, BAYHTR1510LUG, BAYHTR3510LUG	Low	Low
BAYHTR1517BRK	Low	Low
BAYHTR1523BRK	High	High
BAYHTR3517LUG	Low	Low

TEM4A0C42S41SB		
Heater	Minimum Heat Speed Tap	
	With Heat Pump	Without Heat Pump
BAYHTR1504BRK, BAYHTR1504LUG, BAYHTR1505BRK, BAYHTR1505LUG	Low	Low
BAYHTR1508BRK, BAYHTR1508LUG, BAYHTR1510BRK, BAYHTR1510LUG, BAYHTR3510LUG	Low	Low
BAYHTR1517BRK	Low	Low
BAYHTR1523BRK	Med	Low
BAYHTR3517LUG	Low	Low

TEM4A0C48S41SB, TEM4A0C60S51SB		
Heater	Minimum Heat Speed Tap	
	With Heat Pump	Without Heat Pump
BAYHTR1504BRK, BAYHTR1504LUG, BAYHTR1505BRK, BAYHTR1505LUG	Low	Low
BAYHTR1508BRK, BAYHTR1508LUG, BAYHTR1510BRK, BAYHTR1510LUG, BAYHTR3510LUG	Low	Low
BAYHTR1517BRK	Low	Low
BAYHTR1523BRK	Low	Low
BAYHTR1525BRK	Low	Low
BAYHTR3517LUG	Low	Low

Minimum Airflow CFM

**Air Handler and Heater Matrix
Allowable Combinations**

Table 1. TEM4 MINIMUM HEATER AIRFLOW CFM — HEATER MATRIX

Model No.	BAYHTR1504BRK * BAYHTR1504PDC * BAYHTR1504LUG * BAYHTR1505BRK * BAYHTR1505PDC * BAYHTR1505LUG *	BAYHTR1508BRK * BAYHTR1508PDC * BAYHTR1508LUG * BAYHTR1510BRK * BAYHTR1510PDC * BAYHTR1510LUG * BAYHTR3510LUG *	BAYHTR1515BRK * BAYHTR3515LUG *	BAYHTR1517BRK *	BAYHTR3517LUG *	BAYHTR1520BRK *	BAYHTR1521BRK *
TEM4A0B18S21S *	L/L	L/L	--	--	--	--	--
TEM4A0B24S21S *	L/L	L/L	--	--	--	--	--
TEM4A0B30S31S *	L/L	L/L	L/L	L/M	L/H	--	--
TEM4A0C36S41S * (a)	L/L	L/L	L/L	--	--	L/L	--
TEM4A0C42S41S * (a)	L/L	L/L	L/L	--	--	L/L	--
TEM4A0C48S41S * (a)	L/L	L/L	L/L	--	--	--	L/L
TEM4A0C60S51S * (a)	L/L	L/L	L/L	--	--	L/L	--
1. Cooling / HP Airflow 2. * = Followed by two digits							

(a) Taps 1-3 = Low, Tap 4 = Med, Tap 5 = High

Performance and Electrical Data

Table 2. Air Flow Performance

TEM4A0B18S21SB, TEM4A0B24S21SB (a)						
EXTERNAL STATIC (in w.g)	AIRFLOW					
	Speed Taps — 230 VOLTS			Speed Taps — 208 VOLTS		
	High	Med	Low †	High	Med	Low †
0.1	1094	927	773	1052	849	658
0.2	1032	880	735	990	807	624
0.3	955	818	678	915	750	578
0.4	864	739	601	826	679	518
0.5	759	645	505	723	591	441
0.6	639	534	389	606	490	
0.7	505	408		476	374	

1. Values are with wet coil, no filter, and no heaters
2. CFM Correction for dry coil = Add 3%
3. † = Factory setting

(a) For the TEM4A0B24S21SB, the recommended speed tap is medium at 0.4" external static pressure.

Table 3. Electrical Data

TEM4A0B18S21SB, TEM4A0B24S21SB											
Heater Model No.	No. of Circuits/ Phases	240 Volt					208 Volt				
		Capacity		Heater Amps per Circuit	Minimum Circuit Ampacity	Maximum Overload Protection	Capacity		Heater Amps per Circuit	Minimum Circuit Ampacity	Maximum Overload Protection
		kW	BTUH				kW	BTUH			
No Heater				1.2 *	2	15			1.2 *	2	15
BAYHTR1504BRK BAYHTR1504LUG	1/1	3.84	13100	16.0	22	25	2.88	9800	13.8	19	20
BAYHTR1505BRK BAYHTR1505LUG	1/1	4.80	16400	20.0	27	30	3.60	12300	17.3	23	25
BAYHTR1508BRK BAYHTR1508LUG	1/1	7.68	26200	32.0	42	45	5.76	19700	27.7	36	40
BAYHTR1510BRK BAYHTR1510LUG	1/1	9.60	32800	40.0	52	60	7.20	24600	34.6	45	45
BAYHTR3510LUG	1/3	9.60	32800	23.1	30	30	7.20	24600	20.0	26	30

* = Motor Amps

Performance and Electrical Data

Table 4. Air Flow Performance

TEM4A0B30S31SB, TEM4A0B36S31SB						
EXTERNAL STATIC (in w.g)	AIRFLOW					
	Speed Taps — 230 VOLTS			Speed Taps — 208 VOLTS		
	High	Med	Low †	High	Med	Low †
0.1	1391	1305	1059	1338	1146	902
0.2	1305	1231	1029	1257	1098	868
0.3	1203	1138	970	1159	1027	817
0.4	1083	1027	884	1044	935	753
0.5	948	899	769	913	823	664
0.6	795	752	626	766	692	
0.7	626	587		603	542	

1. Values are with wet coil, no filter, and no heaters
2. CFM Correction for dry coil = Add 3%
3. † = Factory setting
4. In downflow applications, airflow must not exceed 1200 cfm due to condensate blowoff.

Table 5. Electrical Data

TEM4A0B30S31SB, TEM4A0B36S31SB											
Heater Model No.	No. of Circuits/ Phases	240 Volt					208 Volt				
		Capacity		Heater Amps per Circuit	Minimum Circuit Ampacity	Maximum Overload Protection	Capacity		Heater Amps per Circuit	Minimum Circuit Ampacity	Maximum Overload Protection
		kW	BTUH				kW	BTUH			
No Heater				2.0 *	3	15			2.0 *	3	15
BAYHTR1504BRK BAYHTR1504LUG	1/1	3.84	13100	16.0	23	25	2.88	9800	13.8	20	20
BAYHTR1505BRK BAYHTR1505LUG	1/1	4.8	16400	20.0	28	30	3.6	12300	17.3	24	25
BAYHTR1508BRK BAYHTR1508LUG	1/1	7.68	26200	32.0	43	45	5.76	19700	27.7	37	40
BAYHTR1510BRK BAYHTR1510LUG	1/1	9.6	32800	40.0	53	60	7.2	24600	34.6	46	50
BAYHTR1517BRK- Circuit 1 ^(a)	2/1	9.6	32800	40.0	53	60	7.2	24600	34.6	46	50
BAYHTR1517BRK- Circuit 2		4.8	16400	20.0	25	25	3.6	12300	17.3	22	25
BAYHTR3510LUG	1/3	9.6	32800	23.1	31	35	7.2	24600	20.0	27	30
BAYHTR3517LUG	1/3	14.4	49100	34.6	45	50	10.8	36900	30.0	40	40
BAYHTR1517BRK with single circuit power source kit BAYSPEKT201A	1/1	14.4	49100	60.0	83	90	10.8	36900	51.9	73	80

* = Motor Amps

^(a) MCA and MOP for circuit 1 contains the motor amps

Performance and Electrical Data

Table 6. Air Flow Performance

TEM4A0C37S31SB						
EXTERNAL STATIC (in w.g)	AIRFLOW					
	Speed Taps — 230 VOLTS			Speed Taps — 208 VOLTS		
	High	Med	Low †	High	Med	Low †
0.1	1959	1704	1344	1786	1465	1154
0.2	1898	1675	1332	1748	1462	1126
0.3	1828	1631	1325	1697	1444	1108
0.4	1750	1574	1310	1633	1410	1095
0.5	1662	1504	1277	1557	1359	1076
0.6	1563	1420	1223	1468	1289	1039
0.7	1452	1321		1365		

1. Values are with wet coil, no filter, and no heaters
2. CFM Correction for dry coil = Add 3%
3. † = Factory setting
4. The recommended speed tap is low at 0.5" external static pressure.
5. In downflow applications, airflow must not exceed 1600 cfm due to condensate blowoff.

Table 7. Electrical Data

TEM4A0C37S31SB											
Heater Model No.	No. of Circuits/ Phases	240 Volt					208 Volt				
		Capacity		Heater Amps per Circuit	Minimum Circuit Ampacity	Maximum Overload Protection	Capacity		Heater Amps per Circuit	Minimum Circuit Ampacity	Maximum Overload Protection
		kW	BTUH				kW	BTUH			
No Heater				2.5 *	3	15			2.5 *	3	15
BAYHTR1504BRK BAYHTR1504LUG	1/1	3.84	13100	16.0	23	25	2.88	9800	13.8	20	20
BAYHTR1505BRK BAYHTR1505LUG	1/1	4.8	16400	20.0	28	30	3.6	12300	17.3	25	25
BAYHTR1508BRK BAYHTR1508LUG	1/1	7.68	26200	32.0	43	45	5.76	19700	27.7	38	40
BAYHTR1510BRK BAYHTR1510LUG	1/1	9.6	32800	40.0	53	60	7.2	24600	34.6	46	50
BAYHTR1517BRK- Circuit 1 ^(a)	2/1	9.6	32800	40.0	53	60	7.2	24600	34.6	46	50
BAYHTR1517BRK- Circuit 2		4.8	16400	20.0	25	25	3.6	12300	17.3	22	25
BAYHTR1523BRK- Circuit 1 ^(a)	2/1	9.6	32800	40.0	53	60	7.2	24600	34.6	46	50
BAYHTR1523BRK- Circuit 2		9.6	32800	40.0	50	50	7.2	24600	34.6	43	45
BAYHTR3510LUG	1/3	9.6	32800	23.1	32	35	7.2	24600	20.0	28	30
BAYHTR3517LUG	1/3	14.4	49100	34.6	46	50	10.8	36900	30.0	40	40

* = Motor Amps

^(a) MCA and MOP for circuit 1 contains the motor amps

Performance and Electrical Data

Table 8. Air Flow Performance

TEM4A0C42S41SB			
EXTERNAL STATIC (in w.g)	AIRFLOW		
	Speed Taps — 208–230 VOLTS		
	High	Med	Low †
0.1	1623	1509	1403
0.2	1583	1465	1357
0.3	1539	1420	1309
0.4	1494	1373	1260
0.5	1450	1326	1211
0.6	1399	1276	1159
0.7	1353	1223	1102

1. Values are with wet coil, no filter, and no heaters
2. CFM Correction for dry coil = Add 3%
3. † = Factory setting
4. Low = Taps 1–3, Med = Tap 4, High = Tap 5
5. In downflow applications, airflow must not exceed 1600 cfm due to condensate blowoff.

Table 9. Electrical Data

TEM4A0C42S41SB											
Heater Model No.	No. of Circuits/ Phases	240 Volt					208 Volt				
		Capacity		Heater Amps per Circuit	Minimum Circuit Ampacity	Maximum Overload Protection	Capacity		Heater Amps per Circuit	Minimum Circuit Ampacity	Maximum Overload Protection
		kW	BTUH				kW	BTUH			
No Heater				4.1 *	5	15			4.1 *	5	15
BAYHTR1504BRK BAYHTR1504LUG	1/1	3.84	13100	16.0	25	25	2.88	9800	13.8	22	25
BAYHTR1505BRK BAYHTR1505LUG	1/1	4.8	16400	20.0	30	30	3.6	12300	17.3	27	30
BAYHTR1508BRK BAYHTR1508LUG	1/1	7.68	26200	32.0	45	45	5.76	19700	27.7	40	40
BAYHTR1510BRK BAYHTR1510LUG	1/1	9.6	32800	40.0	55	60	7.2	24600	34.6	48	50
BAYHTR1517BRK- Circuit 1 ^(a)	2/1	9.6	32800	40.0	55	60	7.2	24600	34.6	48	50
BAYHTR1517BRK- Circuit 2		4.8	16400	20.0	25	25	3.6	12300	17.3	22	25
BAYHTR1523BRK- Circuit 1 ^(a)	2/1	9.6	32800	40.0	55	60	7.2	24600	34.6	48	50
BAYHTR1523BRK- Circuit 2		9.6	32800	40.0	50	50	7.2	24600	34.6	43	45
BAYHTR3510LUG	1/3	9.6	32800	23.1	33	35	7.2	24600	20.0	30	30
BAYHTR3517LUG	1/3	14.4	49200	34.6	48	50	10.8	36900	30.0	42	45

* = Motor Amps

^(a) MCA and MOP for circuit 1 contains the motor amps.

Performance and Electrical Data

Table 10. Air Flow Performance

TEM4A0C48S41SB			
EXTERNAL STATIC (in w.g)	AIRFLOW		
	Speed Taps — 208–230 VOLTS		
	High	Med	Low †
0.1	1784	1698	1634
0.2	1748	1662	1595
0.3	1715	1627	1559
0.4	1682	1591	1521
0.5	1650	1558	1488
0.6	1618	1525	1455
0.7	1499	1494	1422

1. Values are with wet coil, no filter, and no heaters
2. CFM Correction for dry coil = Add 3%
3. † = Factory setting
4. Low = Taps 1–3, Med = Tap 4, High = Tap 5
5. In downflow applications, airflow must not exceed 1600 cfm due to condensate blowoff.

Table 11. Electrical Data

TEM4A0C48S41SB											
Heater Model No.	No. of Circuits/ Phases	240 Volt					208 Volt				
		Capacity		Heater Amps per Circuit	Minimum Circuit Ampacity	Maximum Overload Protection	Capacity		Heater Amps per Circuit	Minimum Circuit Ampacity	Maximum Overload Protection
		kW	BTUH				kW	BTUH			
No Heater				6.0 *	8	15			6.0 *	8	15
BAYHTR1504BRK BAYHTR1504LUG	1/1	3.84	13100	16.0	28	30	2.88	9800	13.8	25	25
BAYHTR1505BRK BAYHTR1505LUG	1/1	4.8	16400	20.0	33	35	3.6	12300	17.3	29	30
BAYHTR1508BRK BAYHTR1508LUG	1/1	7.68	26200	32.0	48	50	5.76	19700	27.7	42	45
BAYHTR1510BRK BAYHTR1510LUG	1/1	9.6	32800	40.0	58	60	7.2	24600	34.6	51	60
BAYHTR1517BRK- Circuit 1 (a)	2/1	9.6	32800	40.0	58	60	7.2	24600	34.6	51	60
BAYHTR1517BRK- Circuit 2		4.8	16400	20.0	25	25	3.6	12300	17.3	22	25
BAYHTR1523BRK- Circuit 1 (a)	2/1	9.6	32800	40.0	58	60	7.2	24600	34.6	51	60
BAYHTR1523BRK- Circuit 2		9.6	32800	40.0	50	50	7.2	24600	34.6	43	45
BAYHTR1525BRK- Circuit 1 (a)	4/1	6.0	20500	25.0	39	40	4.5	15400	21.6	35	35
BAYHTR1525BRK- Circuit 2		6.0	20500	25.0	31	35	4.5	15400	21.6	27	30
BAYHTR1525BRK- Circuit 3		6.0	20500	25.0	31	35	4.5	15400	21.6	27	30
BAYHTR1525BRK- Circuit 4		6.0	20500	25.0	31	35	4.5	15400	21.6	27	30
BAYHTR3510LUG	1/3	9.6	32800	23.1	36	40	7.2	24600	20.0	32	35
BAYHTR3517LUG	1/3	14.4	49100	34.6	50	50	10.8	36900	30.0	44	45

* = Motor Amps

(a) MCA and MOP for circuit 1 contains the motor amps.

Performance and Electrical Data

Table 12. Air Flow Performance

TEM4A0C60S51SB			
EXTERNAL STATIC (in w.g)	AIRFLOW		
	Speed Taps — 208 – 230 VOLTS		
	High	Med †	Low
0.1	1954	1864	1780
0.2	1919	1827	1741
0.3	1885	1791	1704
0.4	1852	1756	1668
0.5	1821	1723	1633
0.6	1790	1691	1599
0.7	1761	1660	1567

1. Values are with wet coil, no filter, and no heaters
2. CFM Correction for dry coil = Add 3%
3. † = Factory Setting
4. Low = Taps 1-3, Med = Tap 4, High = Tap 5
5. BAYTEMDFKT1A must be used for downflow applications and airflow must not exceed 1800 cfm.

Table 13. Electrical Data

TEM4A0C60S51SB											
Heater Model No.	No. of Circuits/ Phases	240 Volt					208 Volt				
		Capacity		Heater Amps per Circuit	Minimum Circuit Ampacity	Maximum Overload Protection	Capacity		Heater Amps per Circuit	Minimum Circuit Ampacity	Maximum Overload Protection
		kW	BTUH				kW	BTUH			
No Heater				6.0 *	8	15			6.0 *	8	15
BAYHTR1504BRK BAYHTR1504LUG	1/1	3.84	13100	16.0	28	30	2.88	9800	13.8	25	25
BAYHTR1505BRK BAYHTR1505LUG	1/1	4.8	16400	20.0	33	35	3.6	12300	17.3	29	30
BAYHTR1508BRK BAYHTR1508LUG	1/1	7.68	26200	32.0	48	50	5.76	19700	27.7	42	45
BAYHTR1510BRK BAYHTR1510LUG	1/1	9.6	32800	40.0	58	60	7.2	24600	34.6	51	60
BAYHTR1517BRK- Circuit 1 ^(a)	2/1	9.6	32800	40.0	58	60	7.2	24600	34.6	51	60
BAYHTR1517BRK- Circuit 2		4.8	16400	20.0	25	25	3.6	12300	17.3	22	25
BAYHTR1523BRK- Circuit 1 ^(a)	2/1	9.6	32800	40.0	58	60	7.2	24600	34.6	51	60
BAYHTR1523BRK- Circuit 2		9.6	32800	40.0	50	50	7.2	24600	34.6	43	45
BAYHTR1525BRK- Circuit 1 ^(a)	4/1	6.0	20500	25.0	39	40	4.5	15400	21.6	35	35
BAYHTR1525BRK- Circuit 2		6.0	20500	25.0	31	35	4.5	15400	21.6	27	30
BAYHTR1525BRK- Circuit 3		6.0	20500	25.0	31	35	4.5	15400	21.6	27	30
BAYHTR1525BRK- Circuit 4		6.0	20500	25.0	31	35	4.5	15400	21.6	27	30
BAYHTR3510LUG	1/3	9.6	32800	23.1	36	40	7.2	24600	20.0	32	35
BAYHTR3517LUG	1/3	14.4	49100	34.6	50	50	10.8	36900	30.0	44	45

* = Motor Amps

^(a) MCA and MOP for circuit 1 contains the motor amps.

Electrical Data

Figure 1. TEM4A0B18-C37

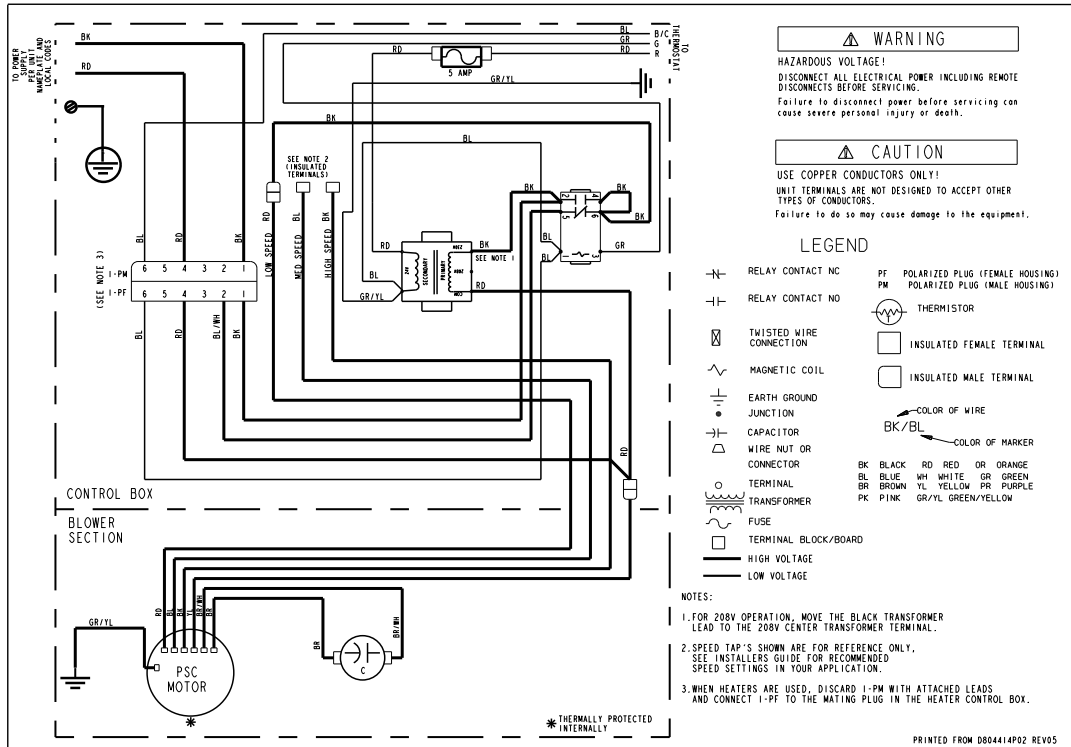
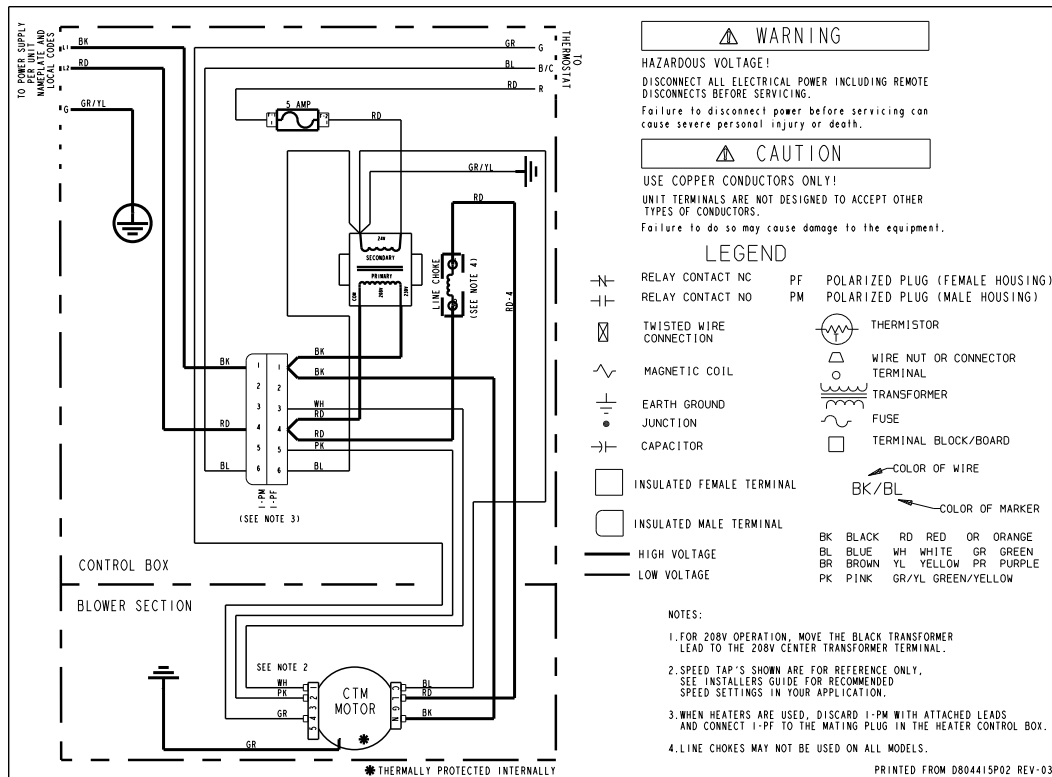
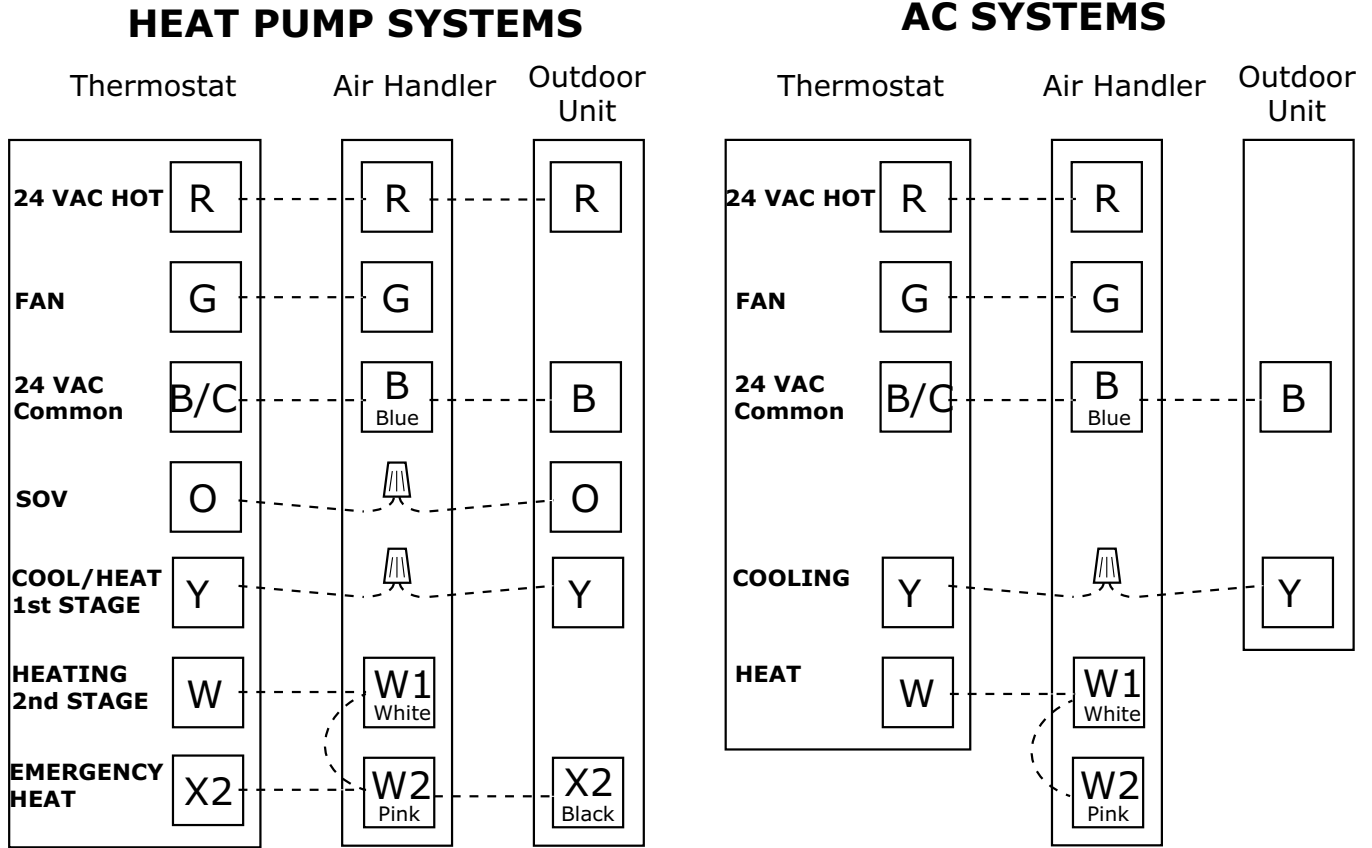

Figure 2. TEM4A0C42-C60



Field Wiring

Figure 3. Field Wiring Diagrams



In AC systems for multiple stages of electric heat, jumper W1 and W2 together if comfort control has only one stage of heat.

TEM Convertibility

Figure 4. Multi-Position Air Handler
* = No Internal Modifications Required.

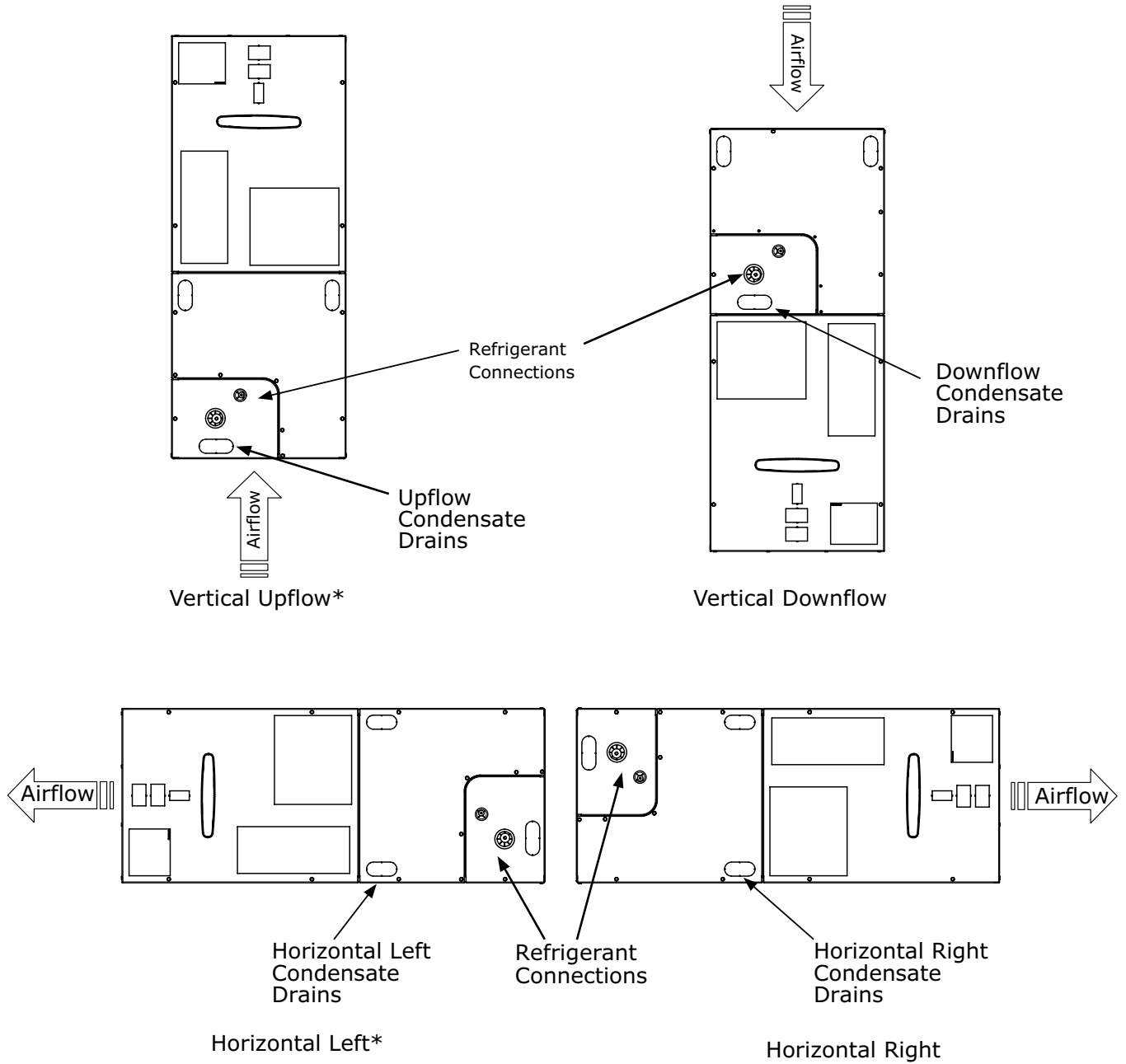

TEM4 Air Handler Dimensional Data

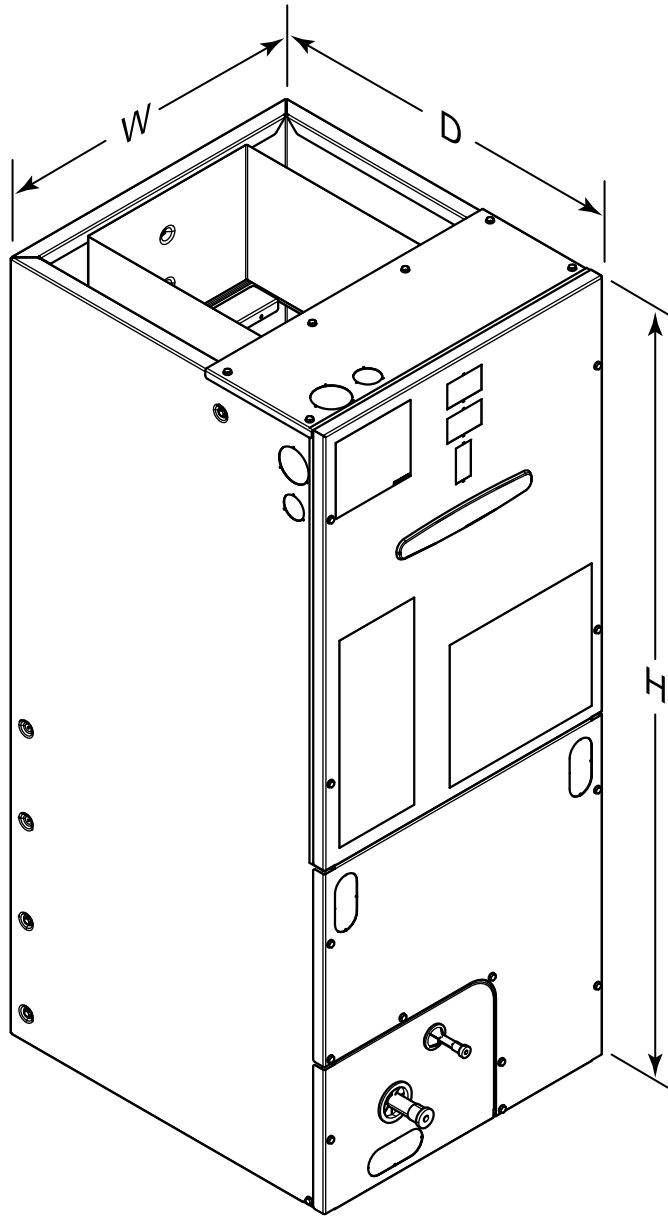

Model No.	H	W	D
TEM4A0B18S21SB	45.02	18.50	21.13
TEM4A0B24S21SB	45.02	18.50	21.13
TEM4A0B30S31SB	45.02	18.50	21.13
TEM4A0B36S31SB	45.02	18.50	21.13
TEM4A0C37S31SB	51.27	23.50	21.13
TEM4A0C42S41SB	51.27	23.50	21.13
TEM4A0C48S41SB	51.27	23.50	21.13
TEM4A0C60S51SB	51.27	23.50	21.13



Ingersoll Rand (NYSE: IR) advances the quality of life by creating comfortable, sustainable and efficient environments. Our people and our family of brands — including Club Car®, Ingersoll Rand®, Thermo King® and Trane® — work together to enhance the quality and comfort of air in homes and buildings; transport and protect food and perishables; and increase industrial productivity and efficiency. We are a global business committed to a world of sustainable progress and enduring results.



ingersollrand.com



Intertek

Ingersoll Rand has a policy of continuous product and product data improvements and reserves the right to change design and specifications without notice.

We are committed to using environmentally conscious print practices.

12-1358-1F-EN 12 Mar 2018

Supersedes 12-1358-1E-EN (January 2018)

©2018 Ingersoll Rand